

DEVELON

Excavators

DX220LC-2N



POWERFUL PRODUCTIVITY JUST RIGHT FOR YOUR PROPER NEEDS

DX220LC-2N makes the best productivity at all job sites.
Superior engine power delivers tireless force and cleverly optimizes it.
With peerless workload and increased digging force,
DX220LC-2N fully unfolds its unrivaled performance at the point of extreme need.



*Option spec info is included to the images contained in
2 this material and may not be the same with the actual specs

INTRODUCING DX220LC-2N

THE BEST FEATURES OF THE PREVIOUS MODEL
HAVE BEEN FULLY RETAINED- WITH EVEN BETTER
ONES ON THE WAY.

DEVELON DL06 ENGINE

- DX220LC-2N runs on DEVELON DL06 engines, one of the most widely-used engines.
- The 6-cylinder engine delivers power up to 146HP (109kW, Net). High power and wide torque range at low RPM, which can also reduce the strain on the clutch and transmission.

FUEL FILLER PUMP

- The fuel filler pump is applied as a standard to all types. It will be a essential feature which gives you chance to decrease the downtime.

* Option spec info is included to the images contained in this material and may not be the same with the actual specs.



QUALITY-PROVEN, RELIABLE FRAMES

DX220LC-2N is built with the frames and hydraulic systems that are proven to be high quality over along period of time.

Count on us for all of your works. Main/bottom frames, undercarriage, swing bearing, sprocket roller, boom and arm are designed for a high degree of durability that you can rely on.

HEAVY-DUTY FRONT

DX220LC-2N is composed of reinforced castings, forged steel pivot points, reinforced heavy-duty arm, and boom to withstand high-impact materials.

- To better protect the base of the arm, reinforced bars have been added and the arm center and end boss have been strengthened.

Travel device, swing device and center joint are also verified for their high quality.



Travel Device



Swing Device



Heavy-Duty Front

BEST IN CLASS EFFICIENCY

POWER MODE

Four different power modes give you precise control over the excavator's powertrain. The system automatically identifies working mode and adjusts engine RPM to supply proper pump torque.



PUMP MATCHING TECHNOLOGY

Engine & pump matching, the new technology of DEVELON, fully resolves problems; low response time of the system, unnecessary fuel consumption. Matching response time between pump and engine efficiently reduces unnecessary fuel consumption as well as exhaust fumes.

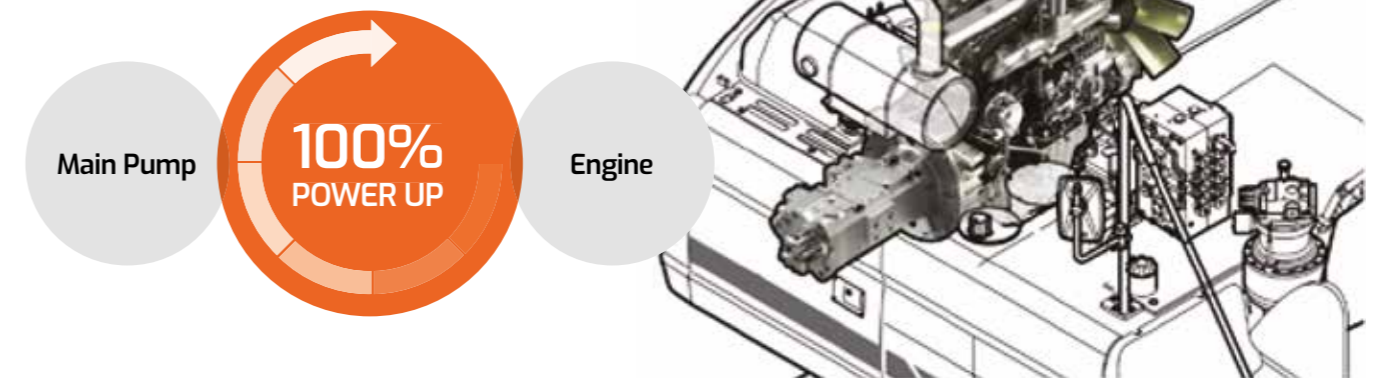

ENHANCED COMFORT AND CONVENIENCE

DX220LC-2N COMES WITH OPTIONS THAT YOU WANTED FOR A LONG TIME. YOU CAN EASILY FIND THE PERFECT LEVEL OF COMFORT WHENEVER YOU COUNT ON IT. EXPERIENCE ANOTHER VERSION OF THE COMFORT THAT YOU HAVE NEVER HAD.



NEW 8-INCH MONITOR

Bigger LCD monitor with user-friendly touch screen panel, allowing easy access to machine settings and maintenance data.

CONTROL LEVER

Precise control increases safety and make tricky operations requiring great precision possible. Simplifying operations makes movement of lifted load safe and calm.

LED WORKING LAMP (OPTIONAL)

LED lamp option is newly added to cabin lamp item. 1,500 lumen LED lights provide much brighter and wider view.

FRONT SLIDING DOOR

The previously fixed front door changed into an openable form. The new model is advantageous for ventilation and temperature control if the front window opens.

SEAT

The quality of the seat is now improved and you can tell the differences easily. Operator can feel more comfortable even with long time operation.

SIDE AND REAR VIEW CAMERA

Side and Rear-view camera keep watch in ways beyond operator's sight. Additional LED lighting system attached on each side for the clear identification.

* Option spec info is included to the images contained in this material and may not be the same with the actual specs.

PRIDE OF DEVELON, MAINTENANCE

DEVELON'S MAINTENANCE SERVICE PROGRAM IS AT YOUR SIDE AND THIS WHOLE NEW DX220LC-2N IS ALSO PART OF IT. TRUST DEVELON.

HIGH-EFFICIENCY ENGINE

- In-house engine with approachable structure.
- Engine bonnet equipped with wide open side panel.

EASY ACCESS TO DAILY MAINTENANCE POINTS

Wide open panels allowing easy access to service points - Allowing quick replacement filters and daily maintenance check easier. Easily accessible filter located at ground level - Located at ground level with wide open side doors.

MY DEVELON (TMS SYSTEM)

- Maintenance data is directly available from control panel.
- Allows daily maintenance check easier.



1 PRE-CLEANER

A rotor type of pre-cleaner in DX220LC-2N filters out particles larger than 20 microns with over 99 % accuracy and attached as a standard option.

2 EASY MAINTENANCE ON RADIATORS

Approach to various radiator is easy, making cleaning easier. Engine part accessibility is also enhanced, can be checked through via top and side panels.

3 WATER SEPARATOR

Highly efficient water separator in fuel to prevent engine damage by removing moisture. Reducing the risk of external engine contamination and lengthen the engine's lifespan.

4 HYDRAULIC OIL RETURN FILTER

Glass fiber filter technology filters out up to 99.5 % of impurities, and increases oil change interval.

MY DEVELON

Telematics Service (OPTIONAL)

TELECOMMUNICATIONS Data flow from machine to web



TELEMATICS TERMINAL

The terminal device is installed and connected to a machine to get machine data.

TELECOMMUNICATION

DEVELON provides Dual mode (Cellular, Satellite) communication to maximize communication coverage

MY DEVELON

Users can monitor the machine status from DEVELON Website & Mobile App

TELEMATICS SERVICE BENEFITS DEVELON and dealer support customers to improve work efficiency with timely and responsive services

CUSTOMER

- Improve work efficiency
- Timely and preventive service
- Improve operator's skills by comparing work pattern
- Manage fleet more effectively

DEALER

- Better service for customers
- Provide better quality of service
- Maintain machine value
- Better understanding of market needs

DEVELON

- Responsive to customer's voice
- Utilize quality-related field data
- Apply customer's usage profile to developing new machine

MAIN FUNCTIONS (WEB/APP) DEVELON Telematics Service provides various functions to support your great performance



OPERATION

You can easily access and manage equipment information and maintenance costs on the platform anytime, anywhere. Retrieve details such as location, uptime, utilization, and fuel costs based on field data, enabling efficient work planning by considering the progress at the job site.



HEALTH

Based on reliable manufacturer information, you can have checklists for each usage cycle and receive replacement cycle reminders for consumable parts. In the event of equipment defects, you will receive notifications and can request service immediately. This ensures swift service support from certified DEVELON dealers and minimizes machine idle time.



E-COMMERCE

You can purchase a variety of digital products and certified genuine parts for your equipment online. Elevate your experience by subscribing to our exclusive digital services.



LIBRARY

Saving your time to find all the documents about your equipment. We provide monthly operation reports, manuals, parts books and more. This helps you to access to a wide range of information and knowledge of your equipment.

GLOBAL PARTS NETWORK

QUALITY-PROVEN MAIN COMPONENTS

Develon provides fast and precise worldwide delivery of genuine Develon parts through its global PDC (parts distribution center) network.



GLOBAL NETWORK

The global network of the GPDC (Global Parts Distribution Center) maximizes its fill rate by making sure that each center is stockpiled with all the critical parts required for businesses in its area. The network also minimizes the time and costs required for parts delivery by positioning PDCs close to major markets around the world. Develon PDCs communicate with customers in their time zone, informing them that they are open for operation, and deliver parts to them as early as possible.

THE GLOBAL PARTS DISTRIBUTION CENTER NETWORK

PDCs had been set up as shown below, including Mother PDC in Ansan, Korea. The ten other PDCs include one in China (Yantai), three in USA (Atlanta, Seattle and Miami), two in Europe (Boom in Belgium and the UK), one in the Middle East (Dubai), two in Asia (Singapore and Indonesia) and one in Brazil (São Paulo).



MPDC : Mother Parts Distribution Center

PDC : Parts Distribution Center

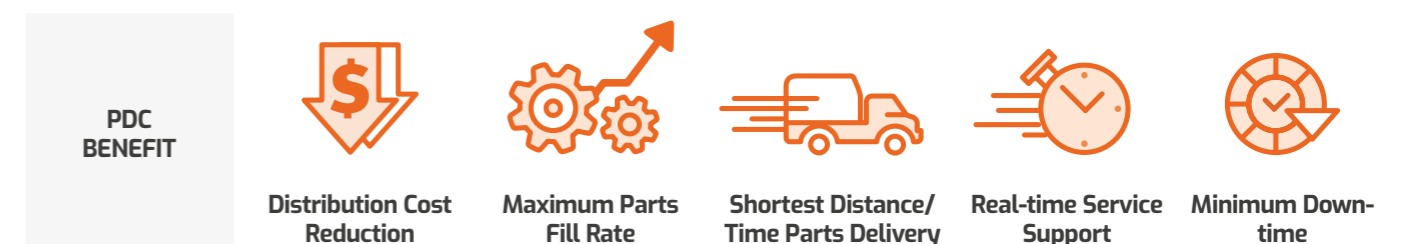

TECHNICAL SPECIFICATIONS

ENGINE

Model	DEVELON DL06
Type	2 valves per cylinder, vertical injectors, water cooled, turbo charged with air to air intercooler. The emission levels are well below the values required for TIER III.
Number of cylinders	6
Rated horse power	113 kW (154 PS) @ 1,800 rpm (SAE J1995, Gross) 109 kW (148 PS) @ 1,800 rpm (SAE J1349, Net)
Max torque	66 kgf.m @ 1,400 rpm
Piston displacement	5,890 cc
Bore x stroke	∅ 100 X 125 mm
Starting motor	24 V x 4.5 kW
Batteries	24 V(12 V x 2 /100 AH)
Air filter	Double element

WEIGHT

5.7 m Heavy Duty Boom, 2.9 m Heavy Duty Arm, 0.92 m³ Bucket, 3.8 Ton Counterweight

Shoe width (mm)	Ground pressure		Machine weight	
	LC Track (kgf/cm ²)	STD Track (kgf/cm ²)	Track (Ton)	STD Track (Ton)
600	0.45	0.48	21.0	20.5
700	0.39	0.42	21.3	20.8
800	0.34	0.37	21.6	21.1

BUCKET DIGGING FORCES

Bucket type	Capacity	Width		Digging force (Ton)
	SAE/PCSA	W/O cutter	With cutter	
GP	0.92	1,316	1,379	(SAE) 12.3, (ISO) 14.0
	1.05	1,458	1,509	
H Class	0.92	1,050	1,096	(SAE) 12.4, (ISO) 13.6
	1.08	1,200	1,246	
	1.40	1,500	1,546	

HYDRAULIC SYSTEM

Main pumps	Swash plate, Axial piston Max. Flow : 2 x 207 l/min Displacement : 2 x 115 cc/rev
Pilot pump	Gear pump - max flow : 27 l/min Pilot pump : 15 cc/rev
Main relief Pressure	Maximum system pressure : 350 kgf/cm ² Main system pressure : 350 kgf/cm ² Travel system pressure : 350 kgf/cm ² Swing system pressure : 270 kgf/cm ²

HYDRAULIC CYLINDERS

The piston rods and cylinder bodies are made of highstrength steel. A shock absorbing mechanism is fitted in all cylinders to ensure shock-free operation and extend piston life.

Cylinders	Quantity	Bore x Rod diameter x Stroke
Boom	2	120 X 85 X 1,263 mm
Arm	1	135 X 95 X 1,443 mm
Bucket	1	115 X 80 X 1,060 mm

UNDERCARRIAGE

Chassis are of very robust construction, all welded structures are designed to limit stresses. High-quality material used for durability. Lateral chassis welded and rigidly attached to the undercarriage. Track rollers lubricated for life, idlers and sprockets fitted with floating seals. Track shoes made of induction-hardened alloy with triple grousers. Heat-treated connecting pins. Hydraulic track adjuster with shock-absorbing tension mechanism.

Upper rollers - 2
Lower rollers - 8 for LC track, 7 for STD track
Track shoes - 49 for LC track, 45 for STD track
Overall track length - 4,445 mm for LC track, 4,065 mm for STD track

ARM DIGGING FORCES

Arm	Length (mm)	Weight (kg)	Digging force (Ton)
HD Arm	2,900	751	(SAE) 9.7, (ISO) 10.0
SHORT Arm	2,400	669	(SAE) 11.2, (ISO) 11.7

SWING MECHANISM

High-torque, axial piston motor with planetary reduction gear bathed in oil. Swing circle is single row, shear type ball bearing with induction-hardened internal gear. Internal gear and pinion gear immersed in lubricant.

Swing speed - 10.29 rpm
Swing Torque - 8.4 ton.m

DRIVE

Each track is driven by an independent, high-torque, axial piston motor through planetary reduction gear. Two levers or foot pedal control provide smooth travel or counter-rotation upon demand.

Travel speed (High / Low) - 2.96 / 5.12 km/h
Maximum traction force - 21.69 / 10.04 ton
Gradeability - 70%

REFILL CAPACITIES

Fuel tank - 400 l
Cooling system (radiator capacity) - 28.8 l
Engine oil - 28 l
Swing drive - 1 x 5 L
Travel reduction gear - 2 x 3.3 L
Hydraulic tank - 195 l

DIMENSIONS

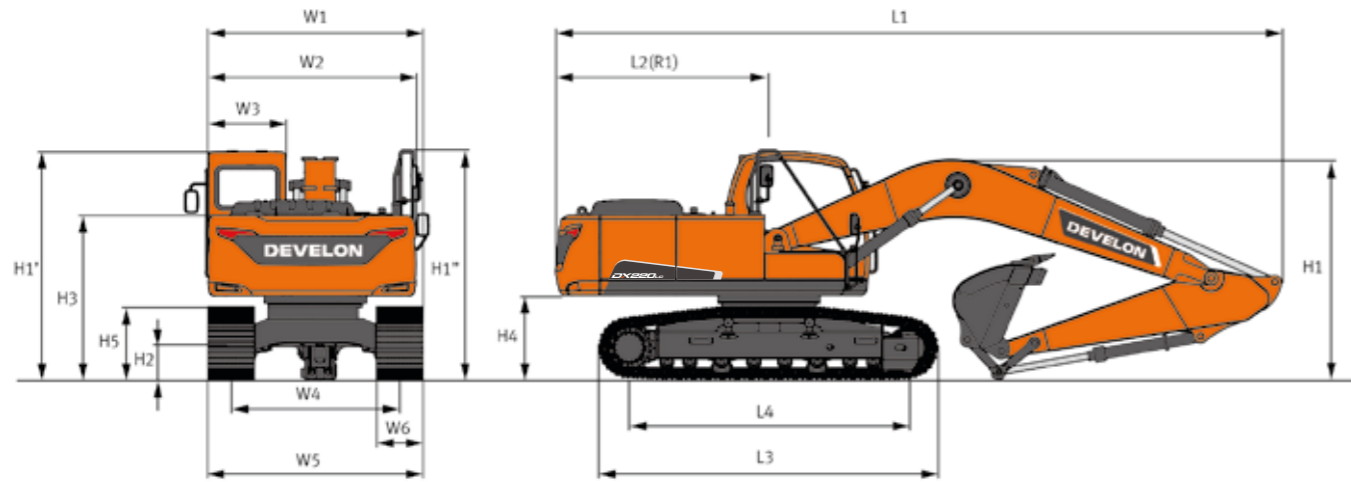

DIMENSIONS

Boom type	Unit		5,700
Arm type	mm		2,900
Bucket type (SAE/PCSA)	mm		0.92/1.08
Overall Length	m ³	L1	9,520
Overall Height	Boom	mm	2,910
	Hose	mm	3,070
	Cabin	mm	2,965
	Hand / Guard Rail	mm	3,175
Overall Width	mm	W1	2,990
Rear Swing Radius	mm	R1	2,855
Ground Clearance*	mm	H2	*450.5
Rear End Distance	mm	L2	2,795
House Width	mm	W2	2,710
Cabin Width	mm	W3	1,010
Height Over Cover	mm	H3	2,135
Counterweight Clearance*	mm	H4	*1065
Track Height*	mm	H5	*900
Track Length (LC Track)	mm	L3	4,445
Track Length (STD Track)	mm	L3	4,065
Tumbler Distance (LC Track)	mm	L4	3,650
Track Gauge	mm	W4	2,390
Undercarriage Width	mm	W5	2,990
Shoe Width	mm	W6	600
Grouser Height	mm		26

(NOTE) * : Without Track Shoe Grouser

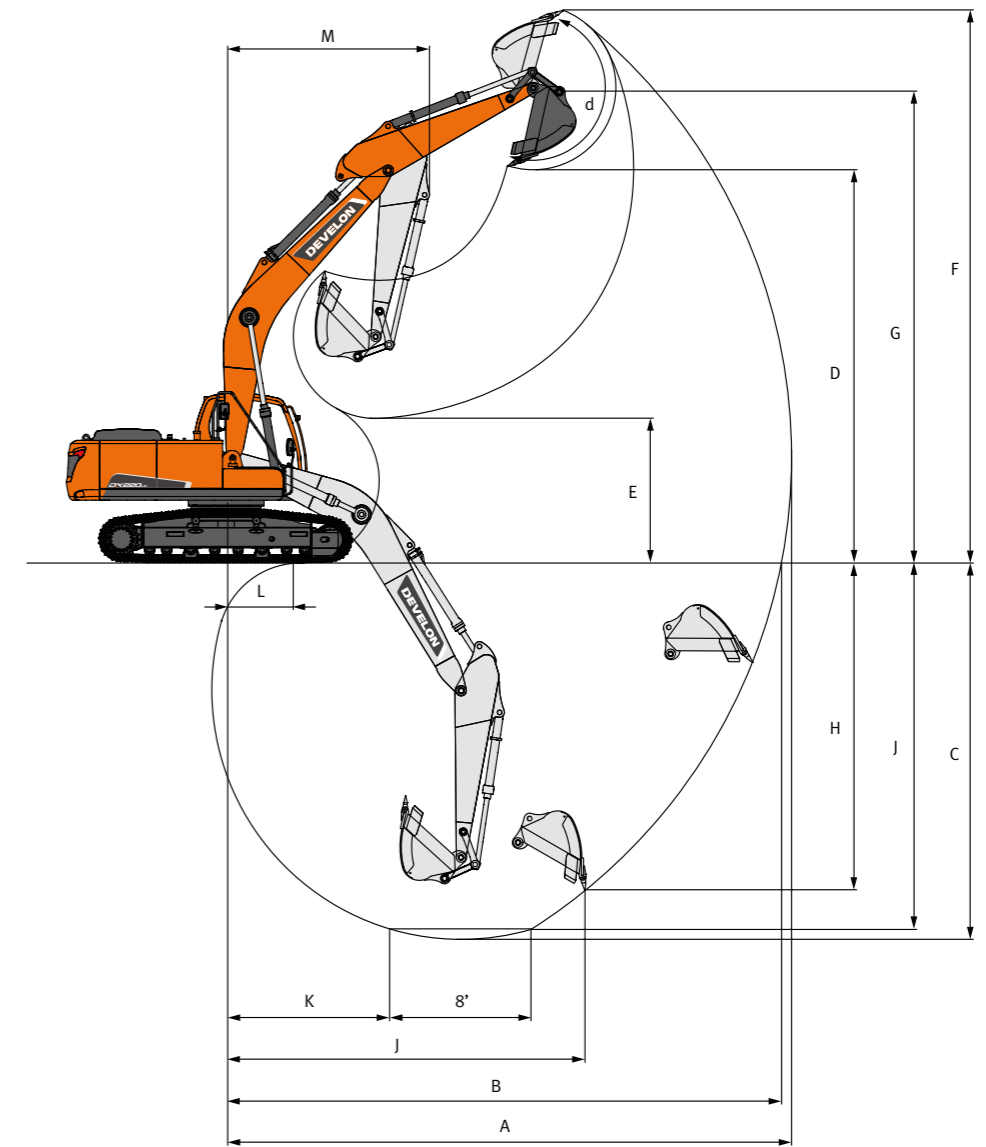

WORKING RANGE

Boom type(One Piece)	Unit		5,700
Arm type	mm		2,900
Bucket type (SAE/PCSA)	m ³		0.92
Max. digging reach	mm	A	9,890
Max. digging reach (ground)	mm	B	9,715
Max. Digging Depth	mm	C	6,615
Max. Loading Height	mm	D	6,810
Min. Loading Height	mm	E	2,470
Max. Digging Height	mm	F	9,620
Max. Bucket Pin Height	mm	G	8,270
Max. Vertical Wall Depth	mm	H	5,705
Max. Radius Vertical	mm	I	6,255
Max. Depth to 2,500mm Line	mm	J	6,420
Min. Radius 2,500mm Line	mm	K	2,820
Min. Digging Reach	mm	L	610
Min. Swing Radius	mm	M	3,570
Bucket Angle	deg	d	176

LIFTING CAPACITY

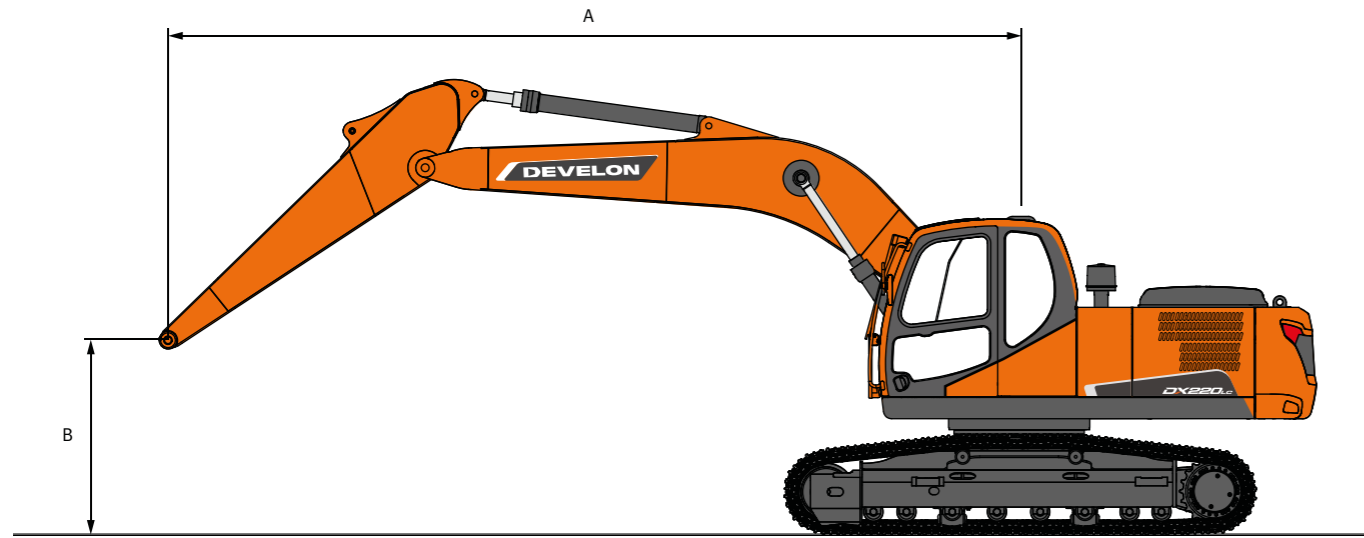

STANDARD

Metric

Boom : 5.700m (18'7") Arm : 2.900m (9'5") Shoe : 600 mm (2'0") Counterweight : 3.840kg (8,466 lb) STD track Unit : 1,000kg

B(m)	A(m)	1.5		3		4.5		6		7.5		Max. Reach		
														A(m)
7.5												4.07 *	4.07 *	6.09
6								4.76 *	4.76 *			3.76 *	3.56	7.25
4.5								5.18 *	4.69	4.80 *	3.22	3.69 *	2.97	7.97
3						7.52 *	6.84	5.87 *	4.43	4.84	3.12	3.79 *	2.68	8.34
1.5						8.93 *	6.29	6.57 *	4.17	4.71	3	4.04	2.57	8.42
0				5.95 *	5.95 *	9.63 *	5.99	6.43	3.99	4.61	2.91	4.13	2.61	8.22
-1.5	6.33 *	6.33 *	10.13 *	10.13 *	9.54 *	5.91	6.35	3.91	4.6	2.89	4.52	2.85	7.72	
-3	10.80 *	10.80 *	12.13 *	11.71	8.68 *	5.99	6.39 *	3.97				5.35 *	3.42	6.85
-4.5			9.05 *	9.05 *	6.55 *	6.25						5.15 *	4.94	5.41

1. AT THE ARM END, WITHOUT BUCKET(Unit : 1,000kg)
2. CAPACITIES MARKED WITH AN ASTERISK (*) ARE LIMITED BY HYDRAULIC CAPACITIES.
3. LIFT CAPACITIES SHOWN DO NOT EXCEED 75 % OF MINIMUM TIPPING LOADS OR 87 % OF HYDRAULIC CAPACITIES.
4. THE LEAST STABLE POSITION IS OVER THE SIDE.
5. LIFT CAPACITIES APPLY ONLY TO THE MACHINE AS ORIGINALLY MANUFACTURED AND NORMALLY EQUIPPED BY THE MANUFACTURER.
6. LIFT CAPACITIES ARE IN COMPLIANCE WITH ISO 10567.

Feet

Unit : 1,000 lb

B(ft)	A(ft)	5		10		15		20		25		Max. Reach		
														A(ft)
25												8.98 *	8.98 *	19.98
20								10.50 *	10.50 *			8.30 *	7.85	23.8
15								11.41 *	10.33	10.59 *	7.11	8.14 *	6.55	26.13
10						16.59 *	15.07	12.94 *	9.76	10.68	6.88	8.34 *	5.91	27.36
5						19.70 *	13.86	14.48 *	9.19	10.39	6.61	8.9	5.66	27.64
0				13.11 *	13.11 *	21.23 *	13.2	14.18	8.79	10.17	6.41	9.11	5.76	26.98
-5	13.95 *	13.95 *	22.34 *	22.34 *	21.04 *	13.02	14	8.63	10.13	6.38	9.96	6.28	25.33	
-10	23.81 *	23.81 *	26.74 *	25.83	19.13 *	13.2	14.08 *	8.74				11.80 *	7.53	22.46
-15			19.96 *	19.96 *	14.44 *	13.79						11.35 *	10.9	17.76

1. AT THE ARM END, WITHOUT BUCKET(Unit : 1,000lb)
 2. CAPACITIES MARKED WITH AN ASTERISK (*) ARE LIMITED BY HYDRAULIC CAPACITIES.
 3. LIFT CAPACITIES SHOWN DO NOT EXCEED 75 % OF MINIMUM TIPPING LOADS OR 87 % OF HYDRAULIC CAPACITIES.
 4. THE LEAST STABLE POSITION IS OVER THE SIDE.
 5. LIFT CAPACITIES APPLY ONLY TO THE MACHINE AS ORIGINALLY MANUFACTURED AND NORMALLY EQUIPPED BY THE MANUFACTURER.
 6. LIFT CAPACITIES ARE IN COMPLIANCE WITH ISO 10567.
- : Rating Over Front
 : Rating Over Side or 360 Degree

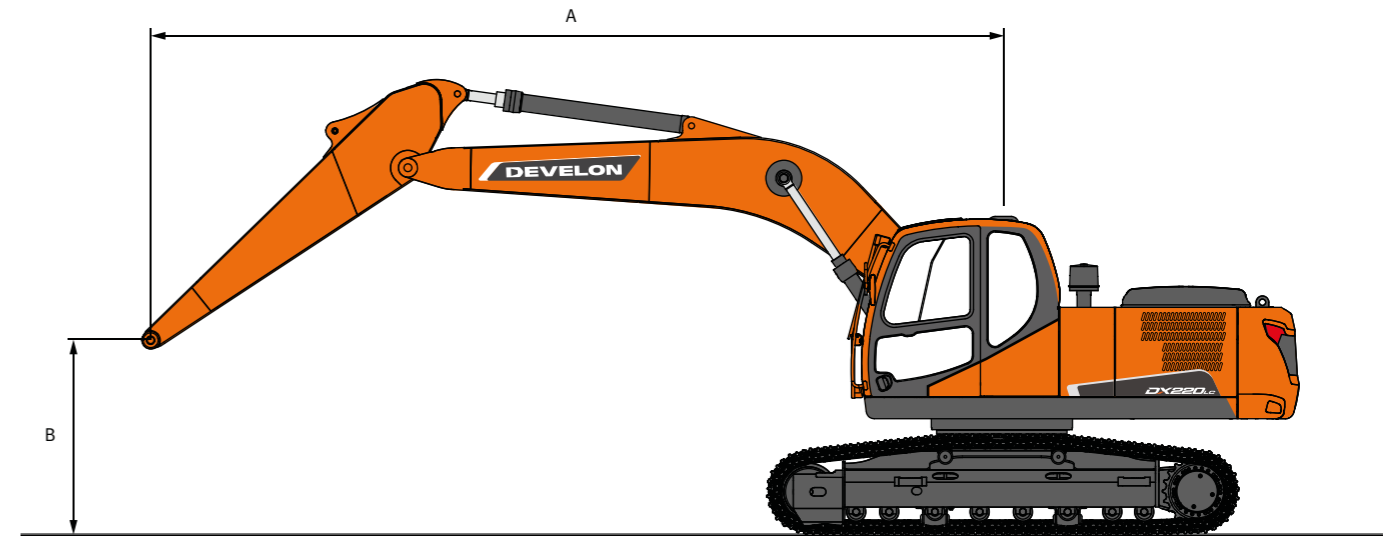

OPTION

Metric

Boom : 5.700m (18'7") Arm : 2.900m (9'5") Shoe : 800 mm (2'6") Counterweight : 3.840kg (8,466 lb) LC track Unit : 1,000kg

B(m)	A(m)	1.5		3		4.5		6		7.5		Max. Reach		
														A(m)
7.5												4.07 *	4.07 *	6.09
6								4.76 *	4.76 *			3.76 *	3.65	7.25
4.5								5.18 *	4.8	4.80 *	3.31	3.69 *	3.05	7.97
3								7.52 *	7	5.87 *	4.54	4.98	3.21	8.34
1.5								8.93 *	6.45	6.57 *	4.28	4.85	3.08	8.42
0				5.95 *	5.95 *	9.63 *	6.15	6.61	4.1	4.75	3	4.25	2.69	8.22
-1.5	6.33 *	6.33 *	10.13 *	10.13 *	9.54 *	6.07	6.53	4.03	4.73	2.98	4.65	2.93	7.72	
-3	10.80 *	10.80 *	12.13 *	12.02	8.68 *	6.15	6.39 *	4.08				5.35 *	3.51	6.85
-4.5			9.05 *	9.05 *	6.55 *	6.42						5.15 *	5.07	5.41

1. AT THE ARM END, WITHOUT BUCKET(Unit : 1,000kg)
2. CAPACITIES MARKED WITH AN ASTERISK (*) ARE LIMITED BY HYDRAULIC CAPACITIES.
3. LIFT CAPACITIES SHOWN DO NOT EXCEED 75 % OF MINIMUM TIPPING LOADS OR 87 % OF HYDRAULIC CAPACITIES.
4. THE LEAST STABLE POSITION IS OVER THE SIDE.
5. LIFT CAPACITIES APPLY ONLY TO THE MACHINE AS ORIGINALLY MANUFACTURED AND NORMALLY EQUIPPED BY THE MANUFACTURER.
6. LIFT CAPACITIES ARE IN COMPLIANCE WITH ISO 10567.

Feet

Unit : 1,000 lb

B(ft)	A(ft)	5		10		15		20		25		Max. Reach		
														A(ft)
25												8.98 *	8.98 *	19.98
20								10.50 *	10.50 *			8.30 *	8.05	23.8
15								11.41 *	10.58	10.59 *	7.3	8.14 *	6.73	26.13
10						16.59 *	15.44	12.94 *	10.01	10.97	7.07	8.34 *	6.08	27.36
5						19.70 *	14.23	14.48 *	9.44	10.68	6.8	8.90 *	5.83	27.64
0				13.11 *	13.11 *	21.23 *	13.56	14.58	9.04	10.47	6.6	9.37	5.93	26.98
-5	13.95 *	13.95 *	22.34 *	22.34 *	21.04 *	13.39	14.4	8.88	10.43	6.57	10.25	6.46	25.33	
-10	23.81 *	23.81 *	26.74 *	26.5	19.13 *	13.57	14.08 *	8.99				11.80 *	7.75	22.46
-15			19.96 *	19.96 *	14.44 *	14.15						11.35 *	11.19	17.76

1. AT THE ARM END, WITHOUT BUCKET(Unit : 1,000lb)
 2. CAPACITIES MARKED WITH AN ASTERISK (*) ARE LIMITED BY HYDRAULIC CAPACITIES.
 3. LIFT CAPACITIES SHOWN DO NOT EXCEED 75 % OF MINIMUM TIPPING LOADS OR 87 % OF HYDRAULIC CAPACITIES.
 4. THE LEAST STABLE POSITION IS OVER THE SIDE.
 5. LIFT CAPACITIES APPLY ONLY TO THE MACHINE AS ORIGINALLY MANUFACTURED AND NORMALLY EQUIPPED BY THE MANUFACTURER.
 6. LIFT CAPACITIES ARE IN COMPLIANCE WITH ISO 10567.
- : Rating Over Front
 : Rating Over Side or 360 Degree

STANDARD & OPTION

STANDARD EQUIPMENT

Front

- 5.7 m Heavy Duty Boom
- 2.9 m Heavy Duty Arm

Hydraulic system

- Boom and Arm flow regeneration
- Boom and Arm holding valves
- Swing anti-rebound valves

Cabin & Interior

- Viscous cab mounts
- E/G RPM control dial
- Serial communication port for laptop PC interface
- Cup holder
- Seat belt
- 12V spare power socket
- Room light
- All weather sound suppressed type CAB.
- 8' Gauge panel (Touch)

Safety

- Handrail and step
- Safety glass
- Hammer for emergency escape
- Battery protector cover

Others

- Double element air cleaner with two stage filtration
- Dry type pre air cleaner
- Two stage water separator
- Fuel filter
- Engine overheat prevention system
- Engine restart prevention system
- Self-diagnostic system
- Alternator (24 V, 60 A)
- Electric horn
- Working lights
- Hydraulic track adjuster
- Track guards
- Greased and sealed track link
- Hydraulic oil tank air breather filter
- Mechanical type Suspension Seat
- Fuel filler pump
- Air Conditioner and Heater

OPTIONAL EQUIPMENT

Some of optional equipments may be standard in some markets. You must check with the local DEVELON dealer to know about the availability or to release the adaptation following the needs of the applications.

Arm

- 2.4 m Heavy Duty Arm

Bucket

- 0.92 m³ General Duty Bucket
- 1.05 m³ General Duty Bucket
- 0.92 m³ H Class Bucket
- 1.08 m³ H Class Bucket
- 1.2m³ H Class Bucket
- 1.4 m³ H Class Bucket
- 0.92 m³ H Class Bucket_Flat
- 1.17 m³ H Class Bucket_Flat

Auxiliary hydraulic

- One-way for Hammer
- Hydraulic Filter for One-way return line
- Breaker

Undercarriage

- Long & Fixed Track
- Standard & Fixed Track
- Undercover for Track Frame
- 600 mm / 700 mm / 800 mm Grouser Shoe

Cabin sub group

- Upper and Lower Guard
- Side Mirror
- 2 Working lamp
- Wiper
- MP3 Radio
- MY DEVELON

We are DEVELON

We trace our roots to 1937 as one of Korea's first large scale machine plant. Throughout time we have consistently delivered exceptional products and solutions.

DEVELON is a bold name that reflects our core ambition to continue developing onwards and leaving behind a positive footprint in our world. Moving forward, we seek to be part of our customers and partners' endeavor to build a better world.

Powered by Innovation

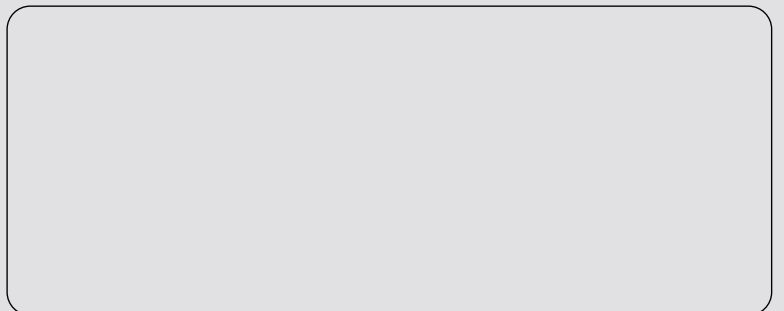

©2025 HD Hyundai Infracore. All rights reserved.

HDIPBE-06-2506

Certain specification(s) are based on engineering calculations and are not actual measurements. Specification(s) are provided for comparison purposes only and are subject to change without notice. Specification(s) for your individual Develon equipment will vary based on normal variations in design, manufacturing, operating conditions, and other factors. Pictures of Develon units may show other than standard equipment.

develon-ce.com