

DOOSAN

Construction Equipment

Special Application

Material Handler / Car Dismantler /
Electric Excavator / Amphibious / Super Long Reach /
High Reach Demolition / Front Shovel



Recycling Industry MATERIAL HANDLER

- DX 190W MH
- DX 210W MH
- DX 180 MH
- DX 225 MH
- DX 300 MH
- DX 340 MH
- DX 420 MH
- DX 520 MH
- DX 800 MH



BENEFIT OF USING MATERIAL HANDLER

- 1 Shorter Horizontal distance from materials
- 2 More height from ground level
- 3 More Handling capacity than SLR (Super Long Reach Front)
- 4 Wider Operator's viewing angle allowing delicate maneuvering of attachment

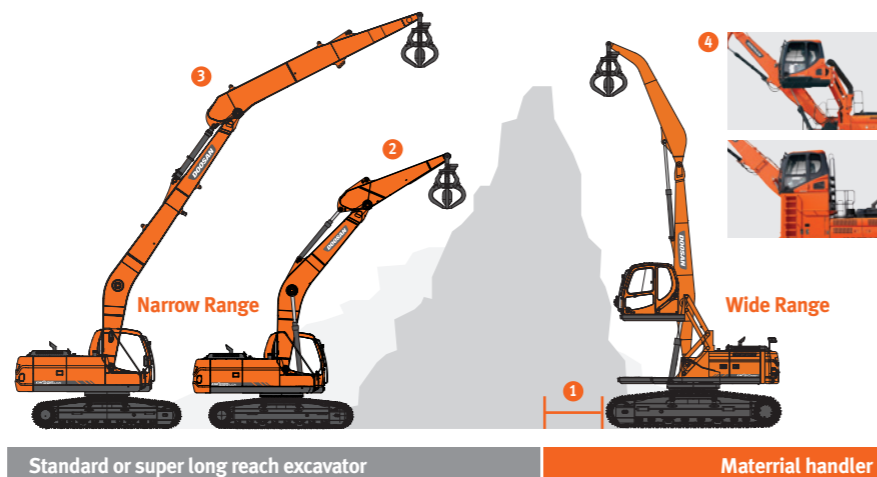

CUSTOMIZED FEATURES

Material Handler is commonly designed for handling metal scrap, industrial waste and garbage in recycling yards or landfill sites. Sometime it also used in loading and unloading materials alongside barges.

SPECIALIZED CABIN / GUARD / FRONT OPTION

Cabin riser system

Provides a stable position to offer wide viewing range.



Elevating cabin system

Provides excellent visibility and high flexibility.



Falling Operator Guard System (FOGS)

Operator protective guard (OPG) on the cabin to protect operator from falling objective from the top.



Lowering cab in emergency

When problem occurred during tilting position, it help the cab to change back into original position.

Straight Linkage Arm Front

Arm for material handler optimized for linkage type attachments.



Gooseneck Arm Front

Arm for material handler optimized for pendulum type attachments.



ATTACHMENTS

VARIOUS SELECTABLE ATTACHMENTS

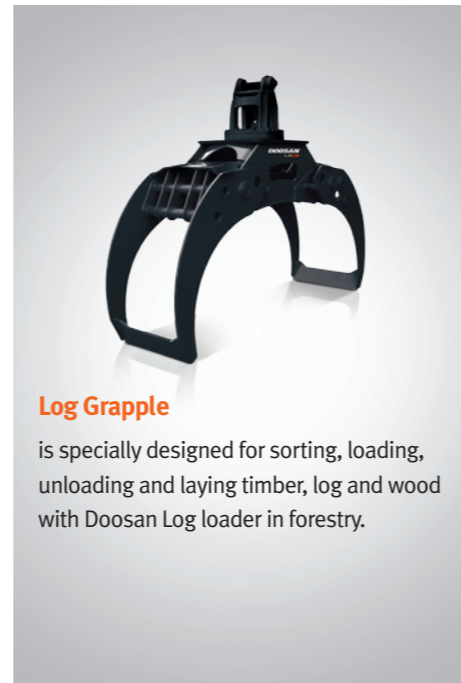
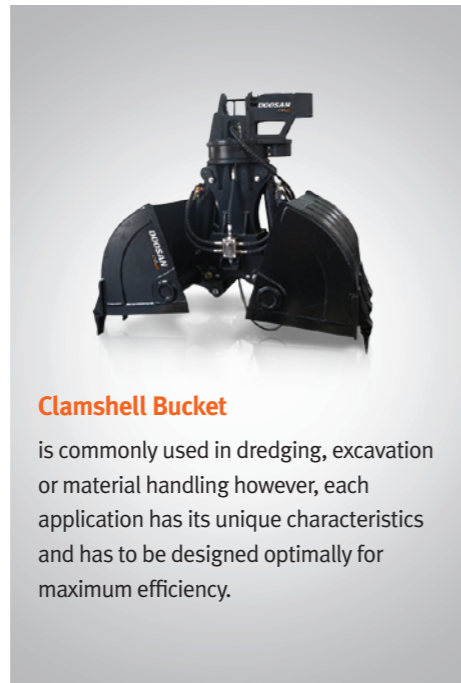

Attachments		Orange Grapple						Clamshell Bucket					
Model		OG18	OG22	OG30	OG34	OG42	OG50	CB14	CB18	CB22	CB25	CB30	CB42
Operating Weight	kg	1,100	1,300	1,700	2,000	2,080	2,500	900	1,200	1,440	1,560	1,920	2,220
Jaw/Bucket Opened Length	mm	1,650	1,840	1,980	2,100	2,100	2,200	1,868	1,868	2,080	2,080	2,135	2,385
Jaw/Bucket Closed Length	mm	1,800	2,090	2,200	2,300	2,350	2,460	1,455	1,455	1,725	1,725	1,985	
Jaw Bucket Width	mm	-	-	-	-	-	-	600	1,100	900	1,100	1,300	1,100
Capacity	m ³	0.40	0.50	0.60	0.72	0.80	0.97	0.40	0.70	0.80	1.00	1.40	1.60

Applicable Carrier	Attachment Availability																						
	DX190W MH	DX210W MH	DX180 MH	DX225 MH	DX300 MH	DX340 MH	DX420 MH	DX520 MH	DX800 MH	OG18	OG22	OG30	OG34	OG42	OG50	CB14	CB18	CB22	CB25	CB30	CB42		
DX190W MH	●									●						●							
DX210W MH		●																●					
DX180 MH	●									●									●				
DX225 MH		●								●													
DX300 MH					●														●				
DX340 MH					●														●				
DX420 MH						●													●				
DX520 MH							●													●			
DX800 MH								●													●		

TECHNICAL SPECIFICATION

DIMENSIONS

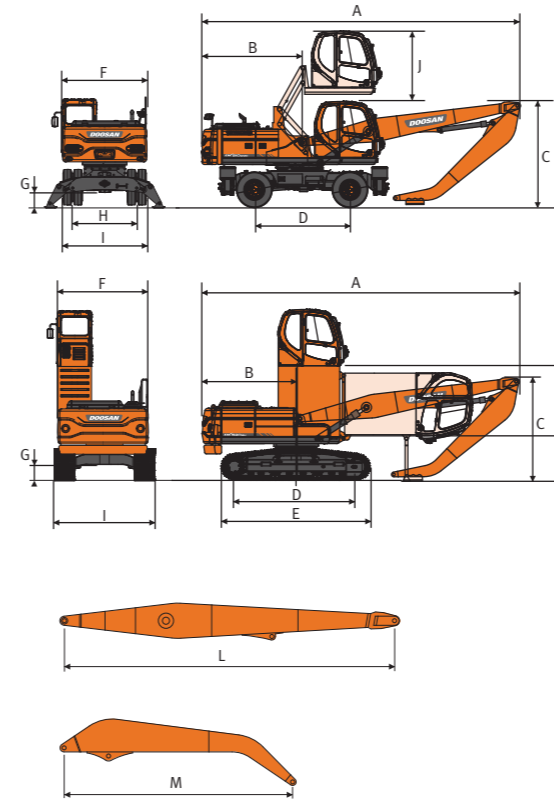

	Unit	DX190W MH	DX210W MH	DX180 MH	DX225 MH	DX300 MH	DX340 MH	DX420 MH	DX520 MH	DX800 MH
A Swing Length	mm	9,476	9,626	9,500	9,650	11,180	12,100	13,270	13,600	14,810
B Tail Swing Radius	mm	2,450	2,850	2,450	2,750	3,200	3,500	3,660	3,700	4,010
C Shipping Height	mm	3,450	3,550	3,400	3,500	4,450	5,600	6,050	6,350	7,710
D Tumbler Distance (Wheel Base)	mm	2,700	2,850	3,180	3,650	4,040	4,040	4,250	4,470	4,730
E Track Length	mm	-	-	3,968	4,445	4,940	4,940	5,200	5,465	5,960
F House Width	mm	2,494	2,530	2,540	2,710	2,960	2,990	2,990	2,990	3,410
G Ground Clearance	mm	350	350	455	480	500	510	540	770	850
H Tread Width	mm	1,944	1,914	-	-	-	-	-	-	-
I Shipping Width	mm	2,494	2,500	2,800	2,990	3,200	3,280	3,350	3,340	3,560
J Elevating Stroke	mm	2,000 / 2,500	2,000 / 2,500	-	-	-	-	-	-	-
K Riser Height	mm	-	-	1,200 / 1,500 / 1,800	1,200 / 1,500 / 1,800	1,200 / 1,500 / 1,800	1,200 / 1,500 / 1,800	1,200 / 1,500 / 1,800	1,200 / 1,500 / 1,800	1,200 / 1,500 / 1,800
L Boom Length	mm	6,100	6,500	6,100	6,500	7,800	8,600	9,600	10,000	11,000
M Arm Length	mm	4,200	4,500	4,200	4,500	5,400	6,050	6,600	7,100	7,500

WORKING RANGES

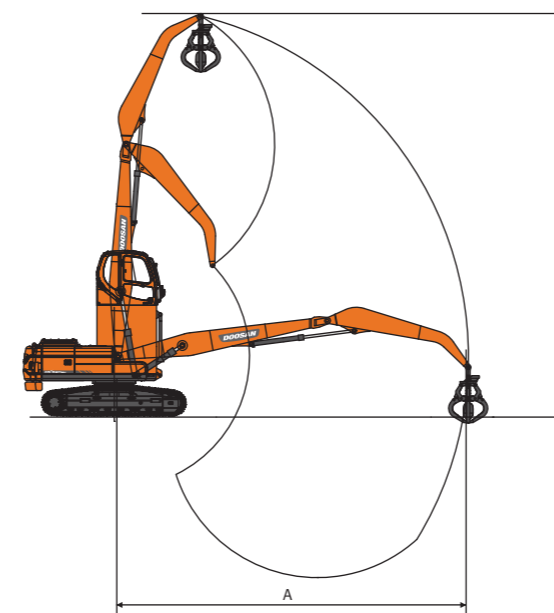

	Unit	DX190W MH	DX210W MH	DX180 MH	DX225 MH	DX300 MH	DX340 MH	DX420 MH	DX520 MH	DX800 MH
A Max. Pin Reach	mm	10,210	10,895	10,000	10,835	12,960	14,385	15,845	16,720	18,240
B Max. Pin Height	mm	11,500	12,140	11,000	12,125	14,130	15,665	16,880	18,135	19,850

DX225 CD



ATTACHMENTS

CAR DISMANTLER & CLAMP ARM



Car Dismantling Crusher
Dismantles/Moves parts by clamping/cutting/rotating actions and separates harness.
- Highly durable hydraulic cylinder
- 360 degree rotation, easy handling
- Highly rigid, lighter weight
- Optimal tooth shape designed for dismantling job
- 4-way cutter blade



Clamp Arm
Fixes car using up/down operation supporting hook for harness dismantling.

Accessory		Crusher
Model		CD22
Gross weight	kg	2,200
Cutting force	ton	226
Max. spread width	mm	600
Cutter length	mm	225
Operating pressure	kgf	320
Hydraulic fluid level	LPM	200~300
Rotation pressure	kgf/cm ²	160
Operating flow rate	LPM	36~40
Attached to excavator	ton	22

Accessory		Clamp Arm
Gross weight	kg	1,295
Length	mm	3,539
Width	mm	1,380
Height	mm	729

BENEFIT OF USING CAR DISMANTLER

Car Dismantling Procedure

- 1 Car warehousing
- 2 Drain all fluids & oils
- 3 Collect recyclable parts
- 4 Dismantle car
- 5 Dismantle engine (if not recyclable)
- 6 Press, breakup, cutoff

Why Dismantling is Needed

In addition to many recyclable parts, cars have a value as a source of raw materials, plastics, glasses and other highly valuable materials such as steel, aluminum, copper etc. A quick and precise dismantling of these parts and materials greatly contributes to making good profit.



Safety

Operator works in a safe cabin. The cabin protects the operator from heat, fire, and explosion etc.

High Efficiency

By labor force: 2-man work, dismantles 1 car a day,
By dismantler: 1-man work, dismantles 25~30 cars a day



TECHNICAL SPECIFICATION

WORKING RANGES (DX225CD)

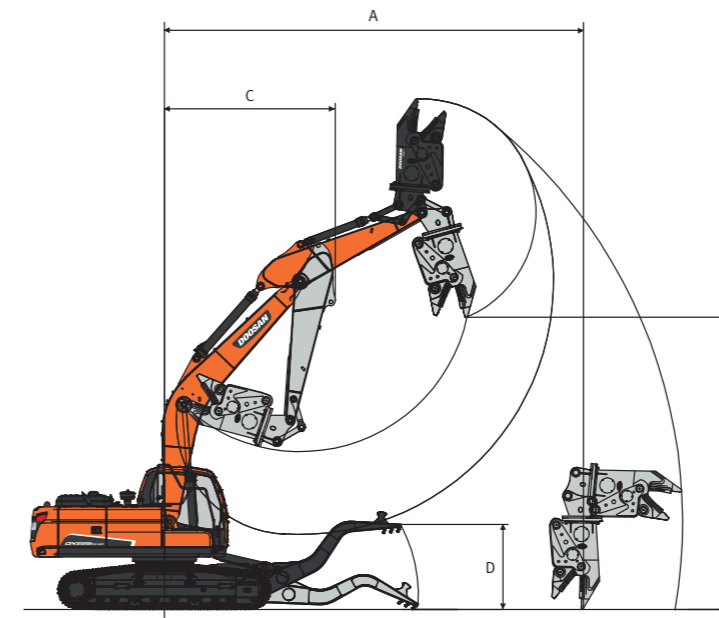

	Unit	DX225CD
Boom	(mm)	5,700
Arm	(mm)	2,900
A Max. horizontal work radius	(mm)	8,739
B Max. work height	(mm)	7,521
C Min. swing radius	(mm)	3,560
D Clamp arm's work height	(mm)	1,776

ELECTRIC EXCAVATOR SYSTEM

- DX 140E
- DX 225E
- DX 300E
- DX 340E
- DX 420E
- DX 520E



ELECTRIC EXCAVATOR SAFETY SYSTEM

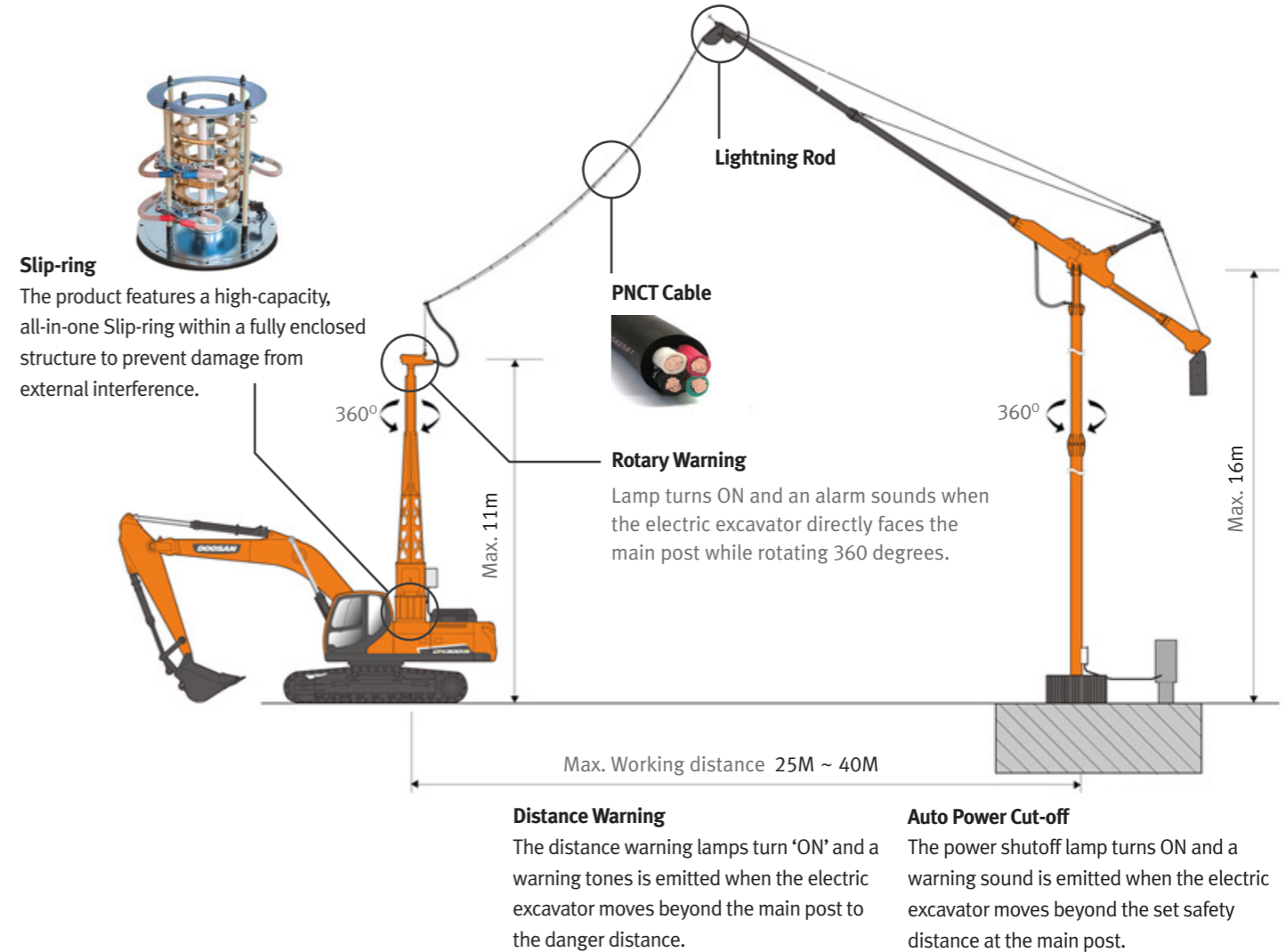

BENEFIT OF USING ELECTRIC EXCAVATOR

REDUCED OPERATING COSTS, ENVIRONMENTAL PROTECTION

Operating costs reduced by 60% compared to engine-operated excavators.
Powerful performance with greater economy.
No engine oil or oil filters required.

[Example]

[Comparison] Total Operating Cost/Year
Working Condition : 8hrs/day x 300days/year



* The above diesel vs. electricity price is based on the Korean market. It may vary in each country and working condition
* The above comparison may very depending on the price of diesel/electricity.

LOW NOISE / LOW VIBRATION

Reduced noise by the improvement of ventilation structure and FAN shape as well as increased stiffness via structural analysis.
Vibration reduced by reducing mechanical and electrical force.

OUTSTANDING MOTOR DURABILITY

Improve durability and environmental integrity, Increase bearing life time with grease injection structure.
Increase Life time of Motor coil with high quality material.



Model	Motor specifications
DX140	90kw (122ps) 4P TE-F
DX220/225	110kw (150ps) 4P TE-F
DX300	160kw (218ps) 4P TE-F
DX340	185kw (251ps) 4P TE-F
DX380/420	225kw (306ps) 4P TE-F
DX480/520	270kw (367ps) 4P TE-F

* The above motor specifications can be changed due to local electricity conditions and are subject to change without notice. Please contact your local distributor for more information.

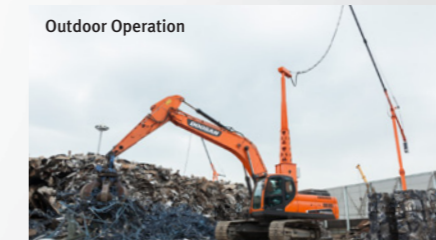

DX 80R AM
 DX 140 AM
 DX 225 AM
 DX 260 AM
 DX 300 AM
 DX 340 AM



BENEFIT OF USING AMPHIBIOUS

Doosan Amphibious is designed to enhance mobility in marshes, swampy area and soft terrain with floating pontoons. Doosan also offer Super Long Reach front kit for more deep and far digging. Using AU kit and SLR kit together, it maximizes versatility of Doosan excavator.

Doosan Amphibious has proven itself and performed exceedingly well in the followings applications :

- Dredging
- Landscaping
- Erosion control and prevention
- Deepening of canal and river deltas
- Maintenance and cleaning of rivers, lakes, shorelines, ponds
- Swamps and soft terrain construction.

CUSTOMIZED FEATURES

AMPHIBIOUS MODULAR DESIGN

- Designed to be easily transported by low bed trailer.
- Both the assembly and disassembly processes can be achieved in under 3 hours if equipped with proper tools and crane.

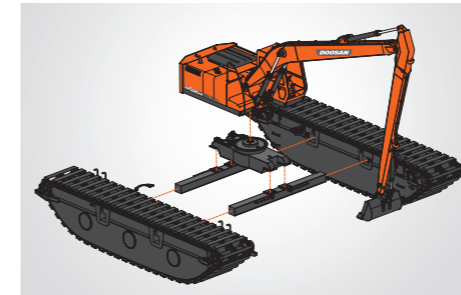

MULTI-SYNCHRONOUS DRIVE SYSTEM

- Motors are mounted on front and rear of each pontoon.
- It offers superior tracking power as compared to a single motor design.

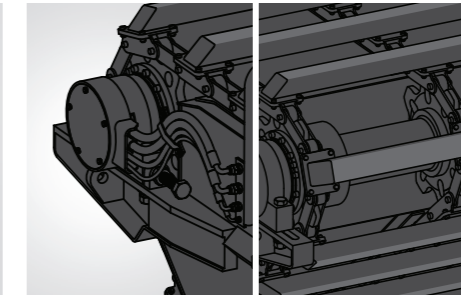

MANHOLE

- Regular inspection and maintenance is very easy because of manholes side pontoon.
- Manhole is designed most suitable position to check inside of pontoon and the size of manhole is big enough to come in and out for a operator.

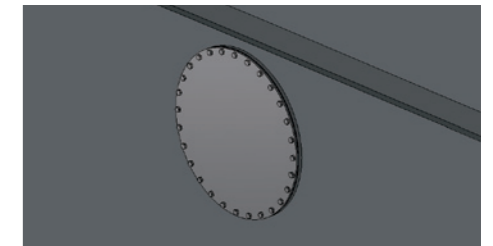

AMPHIBIOUS OPTIONS

SUPPLEMENTARY PONTOONS AND SPUDS (OPTIONAL)

- Supplementary pontoons can be added on each side to boost stability in deeper water operation.
- Spud piles attach to supplementary pontoons help to overcome buoyancy effect, it offers added stability and enhanced operability.

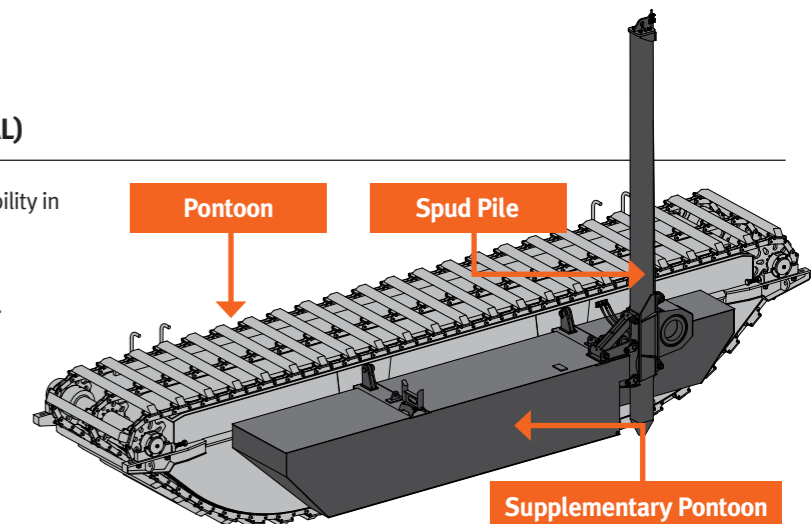

NON HYDRAULIC EXTENDABLE AMPHIBIOUS (STANDARD)

- For non hydraulic extendable design, there are 2 separate locking pin positions for each pontoon on the horizontal mounting beams.
- Users can choose their desired overall track width during the installation process.

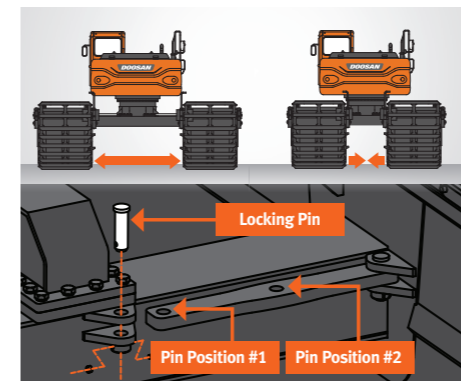

HYDRAULIC EXTENDABLE AMPHIBIOUS & RETRACTABLE PONTOONS (OPTIONAL)

- Designed for ease of land transportation of complete machine by trailer when pontoons are fully retracted.
- Higher ROI through long term saving of manpower, crane hiring and other logistical cost

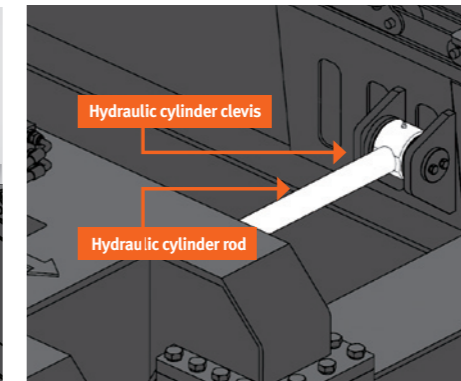

HIGH STRENGTH POLYMER SHOE

- Polymer track shoe can absorb shock from outer impact because it is more resilient than steel.
- Surface of polymer shoe is harder than steel, so it is free from wearing and rust.



ATTACHMENTS

CLAMSHELL BUCKET



Clamshell Bucket

is commonly used in dredging, excavation or material handling however, each application has its unique characteristics and has to be designed optimally for maximum efficiency.

Attachments		Clamshell Bucket		
Model		CB14	CB18	CB25
Operating Weight	kg	900	1,200	1,560
Jaw/Bucket Opened Length	mm	1,868	1,868	2,080
Jaw/Bucket Closed Length	mm	1,455	1,455	1,725
Jaw Bucket Width	mm	600	1,100	1,100
Capacity	m ³	0.37	0.70	1.00
Applicable Carrier	DX140 AM	●		
	DX225 AM	●	●	
	DX260 AM	●	●	
	DX300 AM	●	●	
	DX340 AM		●	●

TECHNICAL SPECIFICATION

DIMENSIONS

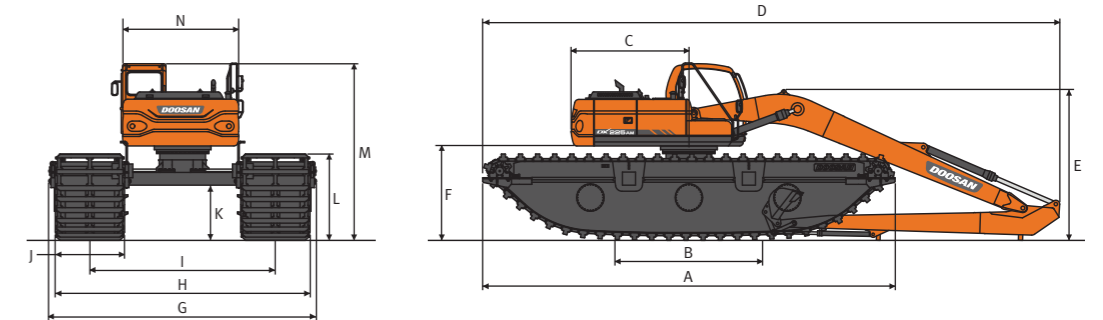

	Unit	DX80R AM	DX140 AM	DX225 AM	DX260 AM	DX300 AM	DX340 AM
Boom Length	mm	3,380	5,570	4,600	7,020	5,700	8,100
Arm Length	mm	1,700	3,400	2,500	5,100	2,900	5,800
Bucket Capacity	m ³	0.28	0.25	0.51	0.40	0.92	0.50
A Max. Track Length	mm	7,000	7,000	9,290	9,290	9,630	9,630
B Track Length on Ground	mm	3,200	3,200	4,500	4,500	4,150	4,150
C Rear Upper Structure Length	mm	1,300	1,300	2,200	2,200	2,750	2,750
D Overall Length	mm	7,825	9,250	9,865	12,240	11,150	13,550
E Height of Boom	mm	2,410	2,800	2,915	2,950	3,375	3,470
F Counterweight Clearance	mm	1,635	1,635	1,835	1,835	2,170	2,170
G Overall Width, min/max (Outwardly extendable)	mm	2,990 / 3,790	2,990 / 3,790	4,220 / 5,320	4,220 / 5,320	4,800 / 6,280	4,800 / 6,280
H Undercarriage Width, min/max	mm	2,990 / 3,790	2,990 / 3,790	3,950 / 5,050	3,950 / 5,050	4,470 / 5,950	4,470 / 5,950
I Track Gauge, min/max	mm	1,860 / 2,660	1,860 / 2,660	2,500 / 3,600	2,500 / 3,600	2,850 / 4,330	2,850 / 4,330
J Track Cleat Width	mm	1,100	1,100	1,450	1,450	1,620	1,620
K Min. Ground Clearance	mm	1,030	1,030	1,140	1,140	1,300	1,300
L Track Height	mm	1,550	1,550	1,690	1,690	2,030	2,030
M Overall Cabin Height	mm	3,540	3,540	3,720	3,720	4,090	4,090
N Upper Structure Overall Width	mm	2,270	2,270	2,540	2,540	2,710	2,710

WORKING RANGE

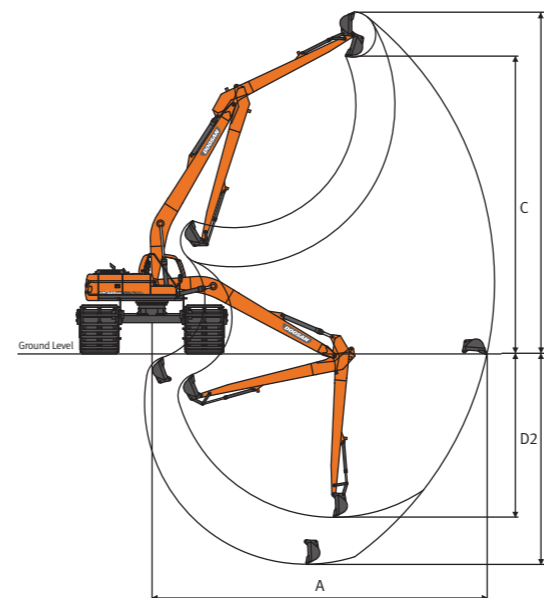

	Unit	DX80R AM	DX140 AM	DX225 AM
Boom Length	mm	3,380	5,570	4,600
Arm Length	mm	1,700	3,400	2,500
Bucket Capacity	m ³	0.28	0.25	0.51
A Recommended Outreach	mm	7,035	9,000	8,315
B Max. Cutting Height	mm	7,875	9,500	9,685
C Max. Loading Height	mm	5,890	8,800	7,355
D1 Max. Digging Depth from Front	mm	3,830	5,000	5,210
D2 Max. Digging Depth from Side	mm	3,130	2,950	3,660

	Unit	DX260 AM	DX300 AM	DX340 AM
Boom Length	mm	5,900	8,550	6,245
Arm Length	mm	3,000	6,030	3,100
Bucket Capacity	m ³	1.10	0.70	1.27
A Recommended Outreach	mm	10,225	15,000	10,830
B Max. Cutting Height	mm	10,935	16,000	11,500
C Max. Loading Height	mm	8,250	14,500	8,455
D1 Max. Digging Depth from Front	mm	6,225	9,500	6,920
D2 Max. Digging Depth from Side	mm	4,070	8,000	4,775

Construction & Maintenance SUPER LONG REACH



DX 140 SLR
DX 225 SLR
DX 260 SLR
DX 300 SLR
DX 340 SLR
DX 420 SLR
DX 520 SLR
DX 800 SLR

BENEFIT OF USING SUPER LONG REACH



TECHNICAL SPECIFICATION

DIMENSIONS

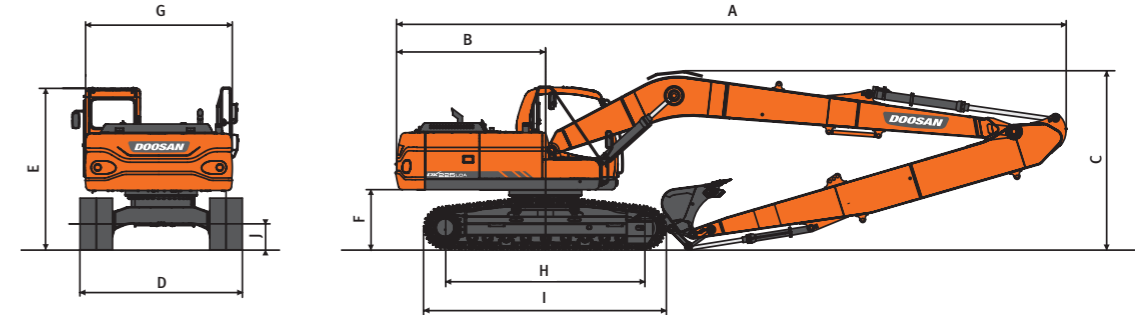

	Unit	DX140 SLR	DX225 SLR	DX260 SLR	DX300 SLR	DX340 SLR	DX420 SLR	DX520 SLR	DX800 SLR
Boom Length	mm	7,000	8,500	9,300	10,000	10,500	10,700	11,000	11,000
Arm Length	mm	5,000	6,200	6,800	7,000	7,500	7,600	8,000	8,000
Bucket Capacity	m ³	0.28	0.39	0.50	0.64	0.70	0.80	0.92	1.64
A Shipping Length	mm	10,120	12,317	14,350	14,370	15,310	15,250	16,090	15,805
B Tail Swing Radius	mm	2,200	2,750	3,035	3,200	3,500	3,660	3,700	4,010
C Shipping Height	mm	2,746	3,254	3,910	3,455	3,765	3,800	4,070	7,120
D Shipping Width	mm	2,590	2,990	3,200	3,200	3,280	3,350	3,340	3,560
E Height over Cabin	mm	2,773	2,975	2,970	3,065	3,125	3,154	3,350	3,530
F C/Weight Clearance	mm	894	1,055	1,110	1,150	1,195	1,265	1,460	1,540
G House Width	mm	2,540	2,710	2,710	2,960	2,990	2,990	2,990	3,410
H Tumbler Distance	mm	3,034	3,650	3,835	4,040	4,040	4,250	4,470	4,730
I Track Length	mm	3,755	4,445	4,625	4,940	4,940	5,200	5,465	5,960
J Gound Clearance	mm	410	480	450	500	510	540	770	850

WORKING RANGES

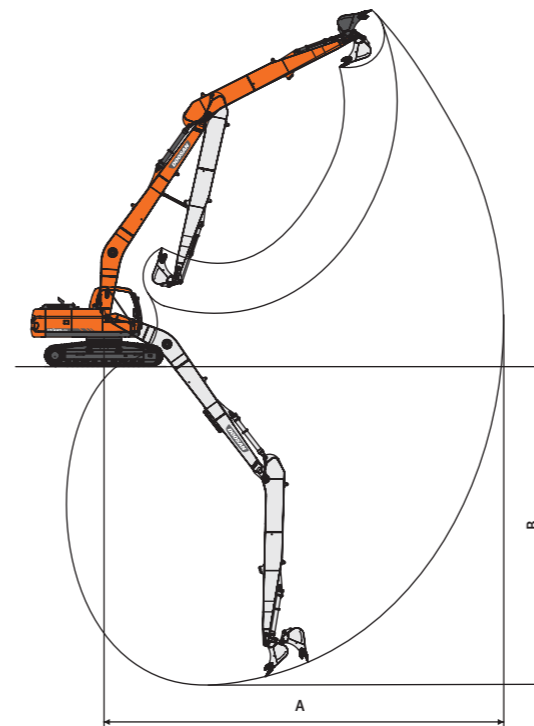

	Unit	DX140 SLR	DX225 SLR	DX260 SLR	DX300 SLR
A Max. Digging Reach	mm	12,150	15,380	16,500	17,520
B Max. Digging Depth	mm	9,840	11,660	12,500	13,875

	Unit	DX340 SLR	DX420 SLR	DX480/520 SLR	DX800 SLR
A Shipping Length	mm	18,550	19,000	19,610	20,100
B Gound Clearance	mm	14,510	14,800	15,130	14,450

Demolition

HIGH REACH DEMOLITION



DX 300 DM
 DX 340 DM
 DX 420 DM
 DX 520 DM
 DX 800 DM

BENEFIT OF USING HIGH REACH DEMOLITION

- 1 Shorter Horizontal distance from buildings
- 2 More height from ground level
- 3 Higher and Wider Operator's viewing angle 30° allowing operators to see the top of the building and control ATT delicately

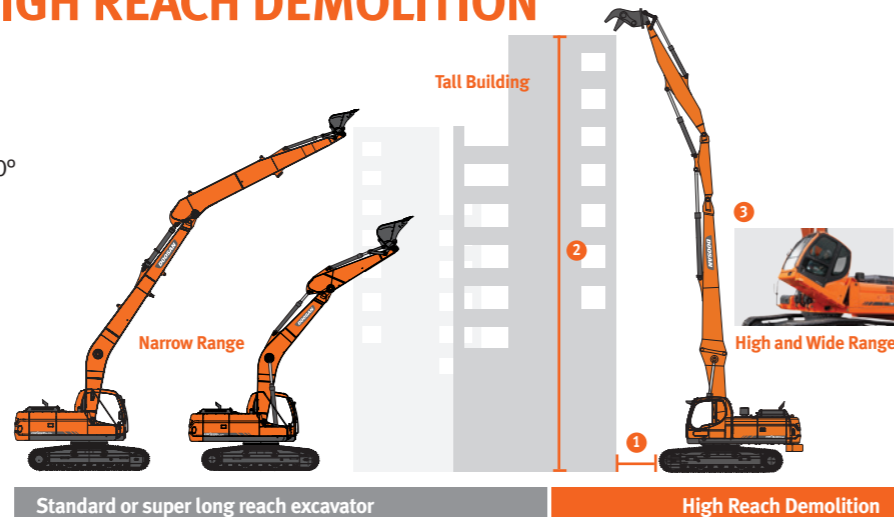

CUSTOMIZED FEATURES

High Reach demolition is mainly designed for more productive, cost-effective and safe tearing-down of buildings and other structures.

- Minimalized damage to surrounded building
- Secured operator's safety
- Maximized work efficiency though easy access to building by 3 pieces front parts.

OPTIMIZED FRONT LINKAGE PART

During the demolishing, if front angle drop down to certain angle could be occurred safety issue, it warns to operator to adjust working front angle.

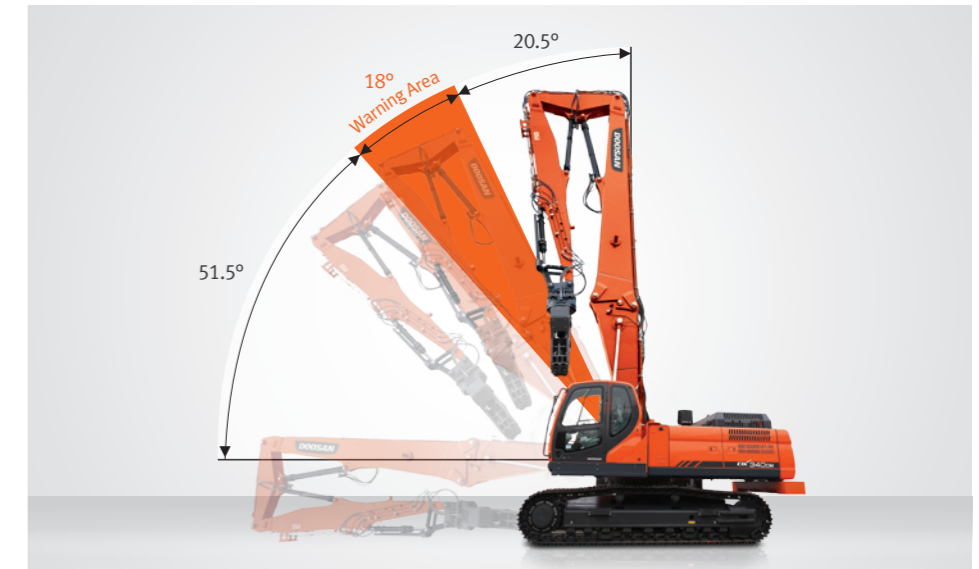

SPECIALIZED DEMOLITION OPTION



Water Spray System (Optional)

For controlling dust from demolishing, optional water spray system is available.



CCTV Camera on end arm & Monitor inside cabin (Optional)

Optional Camera located on end-arm support to secure visibility over 20m height.



Digging front (Optional)

Digging front package available
 Boom can be divided for the machine to use standard excavation purpose.

SPECIALIZED CABIN & GUARD OPTION

Titling Cabin system

The cabin tilted to about 30° degrees upward by hydraulic cylinder offer to observe the top of the building and to control the attachment delicately.



Falling Operator Guard System (FOGS)

Operator protective guard (OPG) on the cabin to protect operator from falling objective from the top.



Demolition

HIGH REACH DEMOLITION

ATTACHMENTS

FIXED PULVERIZER / ROTATING CRUSHER / MULTIPROCESSOR



Fixed Pulverizer
is designed for both primary demolition work and secondary concrete reduction. For secondary demolition, it is ideal for breaking out concrete from fixed structure, pulverizing concrete, separating different materials for recycling, and cutting reinforced rods and small steel profile.



Rotating Crusher
is designed for both primary demolition work and secondary concrete reduction. Especially for secondary demolition, it is ideal for breaking out concrete from fixed structure, pulverizing concrete, separating different materials for recycling, cutting reinforced rods and small steel profile, and working with high reach boom.



Multi-Processor
is designed for all demolition sites by interchanging jaw sets mounted on a single base unit.

Attachments		Fixed Pulverizer			Rotation Crusher			Multi Processor			
Model		FP22	FP25	FP34	RC22	RC25	RC34	MP22-C	MP22-D	MP22-P	MP22-S
Operating Weight	kg	1,375	1,890	2,745	1,780	2,300	2,950	2,040	2,050	2,210	1,880
Overall Length	mm	1,985	2,206	2,388	2,078	2,474	2,686	2,326	2,291	2,342	2,175
Jaw Width (Fixed/Moving Jaw)	mm	438/350	470/346	532/370	438/350	470/346	532/370	1,438	1,368	1,508	1,083
Max. Jaw Opening	mm	732	889	1,061	732	925	1,056	903	797	89	503
Max. Operating Pressure	bar	350	350	350	350	350	350	350	350	350	350
Crushing/Closing Force (tip)	ton	54	64	78	56	67	78	68	70	64	80
Cutter Blade Length	mm	240	360	360	240	360	360	237	355	237	348
Required Oil Flow	lpm	150~250	150~250	200~300	150~250	150~250	200~300	150~250	150~250	150~250	150~250
Applicable Carrier	DX300 DM	●	●		●			●	●	●	●
	DX340 DM	●	●		●			●	●	●	●
	DX420 DM	●	●		●	●		●	●	●	●
	DX520 DM	●	●	●	●	●		●	●	●	●
	DX800 DM		●	●	●	●	●	●	●	●	●

TECHNICAL SPECIFICATION

DIMENSIONS

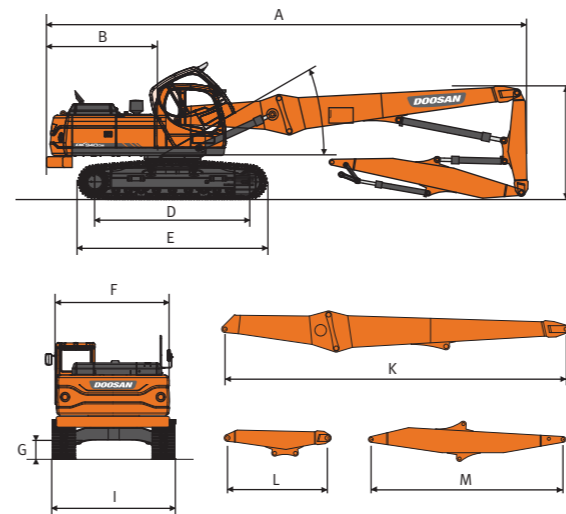

	Unit	DX300 DM	DX340 DM	DX420 DM	DX520 DM	DX800 DM	
A	Shipping Length	mm	12,940	14,650	15,830	18,100	22,210
B	Tail Swing Radius	mm	3,200	3,500	3,660	3,700	4,010
C	Shipping Height	mm	3,370	3,450	3,450	3,720	3,850
D	Tumbler Distance	mm	4,040	4,040	4,250	4,470	4,730
E	Track Length	mm	4,940	4,940	5,200	5,465	5,960
F	House Width	mm	2,960	2,990	2,990	2,990	3,410
G	Ground Clearance	mm	500	510	540	770	850
I	Shipping Width	mm	3,200	3,280	3,350	3,340	3,560
J	Cabin Tilting Angle	degree	35°	35°	35°	35°	35°
K	Boom Length	mm	9,100	10,500	11,700	13,700	17,400
L	Middle Arm Length	mm	2,600	2,600	2,600	2,700	2,700
M	End Arm Length	mm	5,000	6,500	7,000	8,000	10,600

WORKING RANGES

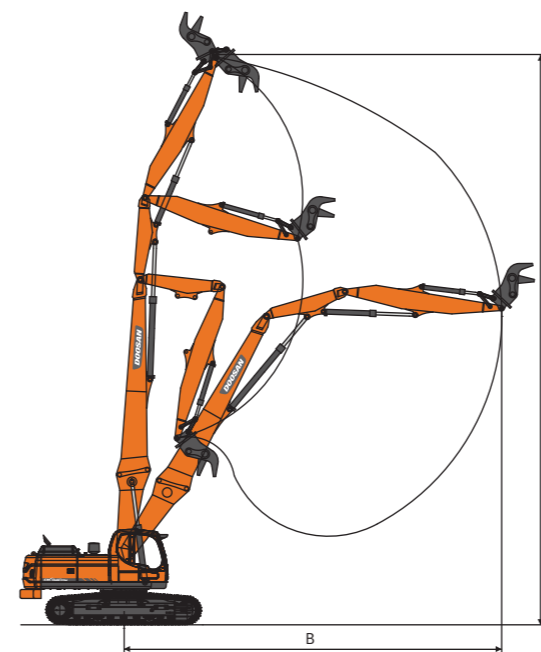

	Unit	DX300 DM	DX340 DM	DX420 DM	DX520 DM	DX800 DM	
A	Max. Pin Height	mm	18,095	21,215	22,890	26,180	32,900
B	Max. Pin Reach	mm	10,315	12,065	13,435	13,840	18,000

Quarry & Mining FRONT SHOVEL

DX 340 FS
DX 420 FS
DX 520 FS
DX 800 FS



Front Shovel is the machine to dig and dump big volume material at one time. It can put stone, gravel, soil or sand to dump truck from ground surface. Working range is short and shovel bucket is rotated in the opposite direction to the general excavator's backhoe for quick working with approached truck.

OPTIMIZED FRONT LINKAGE PART



Durable front linkage

Designed highly reinforced box section and used high strength steel for enhancing strength

Parallel cylinders for high penetration

keep the bucket parallel for supporting bucket performance during the work cycle.

Piping protection Shield

used high strength steel for protecting piping

SPECIALIZED OPTION

Cabin riser system

Provides a stable position to offer wide viewing range.



Falling Operator Guard System (FOGS)

Operator protective guard (OPG) on the cabin to protect operator from falling objective from the top.



BENEFITS OF USING FRONT SHOVEL

Enhanced working mechanism

- Shorter Cycle time Increases unit per hour.

High working efficiency

- Accessibility to the rugged terrain.
- Perfect match with Doosan ADT.
- Cost saving effect such as Labor and Fuel consumption.

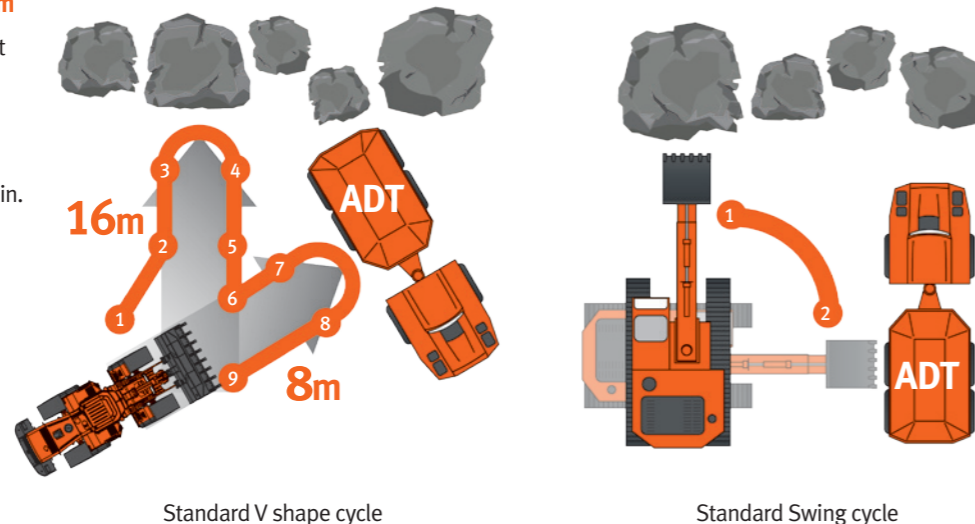

OPTIMIZED SHOVEL BUCKET

Material such as :

Ripped basalt, caliche, shot granite, high silica sand, sharp rock and others.

Features & Benefits

Spill guard is applied to load more capacity. High grade material composition for better durability

- Added more patches for durability and strength on lip plate and inner shell
- Muscle pack heels to increase durability and protect shell from wear.

Types of lip plate shape focused on performance

Straight shape

Designed for :

Multi purposed digging and loading in almost all of general job site.

Features & Benefits

Even distributed breakout force on the all bucket tooth. Especially higher efficiency for normal duty digging and loading.

V-shape

Designed for :

Face or bank loading in mining or quarry applications.

Features & Benefits

Optimized penetration for high resistance material such as blasted rock.
- 150~160 O tapered lip plate reduce the penetration resistance.
Increased anti-abrasion life for lip plate.

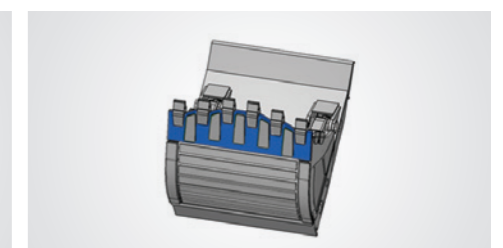
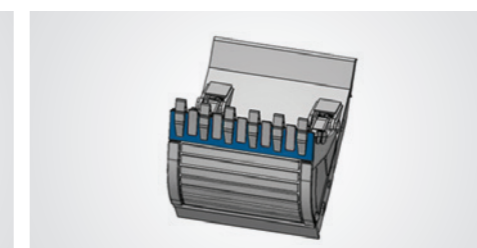
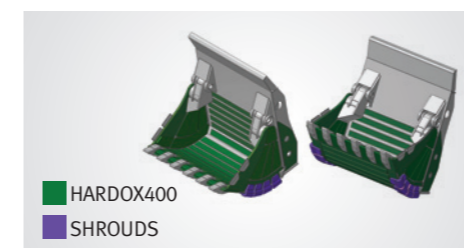

TECHNICAL SPECIFICATION

DIMENSIONS

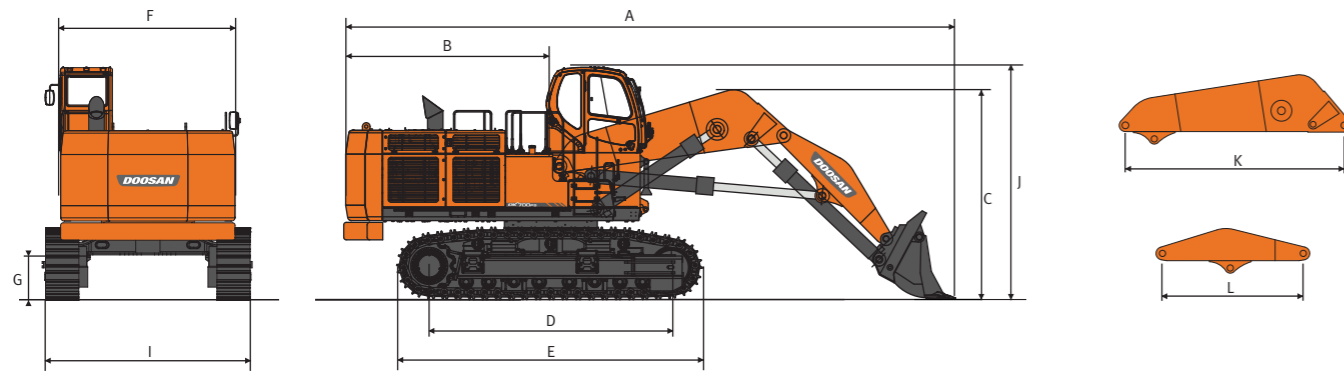

	Unit	DX340 FS	DX420 FS	DX480/520 FS	DX800 FS	
A	Shipping Length	mm	11,540	11,950	12,045	12,900
B	Tail Swing Radius	mm	3,500	3,660	3,700	4,010
C	Shipping Height	mm	3,670	3,950	4,210	4,500
D	Tumbler Distance	mm	4,040	4,250	4,470	4,730
E	Track Length	mm	4,940	5,200	5,465	5,960
F	House Width	mm	2,990	2,990	2,990	3,410
G	Ground Clearance	mm	510	540	770	850
I	Shipping Width	mm	3,280	3,350	3,340	3,560
J	Height over Cabin	mm	3,125	3,154	3,350	3,530
K	Boom Length	mm	3,850	4,200	4,300	4,500
L	Arm Length	mm	2,750	2,800	2,800	3,000
-	Bucket Capacity	m ³	2.0	2.3	2.6	4.5

ARM CROWD FORCE & BUCKET BREAKOUT FORCE

	Unit	DX340 FS	DX420 FS	DX520 FS	DX800 FS
Arm Crowd Force	ton	19.2	22.1	25.3	27.4
Bucket Breakout Force	ton	29.4	31.7	36.9	40.7

TECHNICAL SPECIFICATION

WORKING RANGE

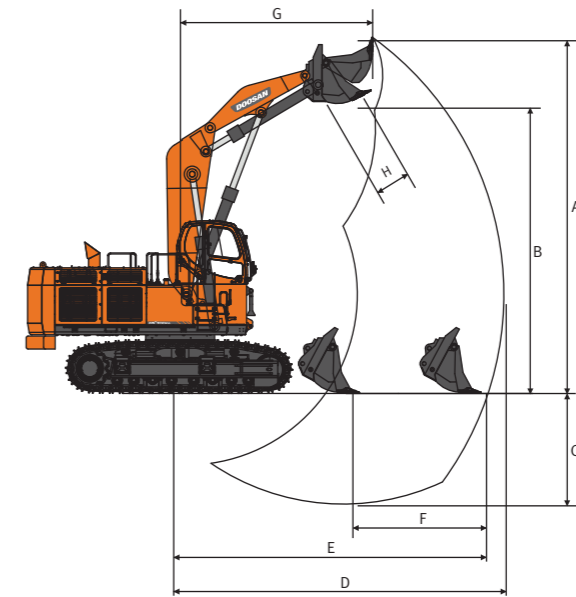

	Unit	DX340 FS	DX420 FS	DX480/520 FS	DX800 FS	
A	Max. Digging Height	mm	9,505	10,000	10,415	11,250
B	Max. Dumping Height	mm	7,240	6,870	7,285	8,050
C	Max. Digging Depth	mm	2,755	3,900	3,365	4,150
D	Max. Digging Reach	mm	8,510	8,840	8,930	9,400
E	Max. Digging Reach (Ground)	mm	8,045	8,280	8,345	8,600
F	Level Crowding Distance	mm	3,330	3,340	3,380	3,200
G	Reach at Max. Dumping Height	mm	3,060	3,840	3,720	4,300
H	Max. Bucket Opening Width	mm	1,255	1,450	1,450	1,600



EXCAVATOR



WHEEL LOADER

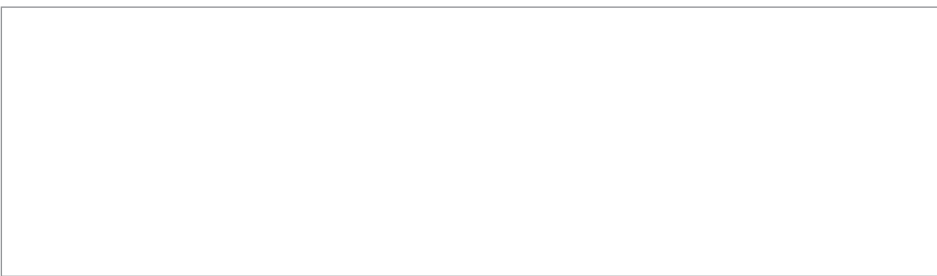

Doosan Infracore Co., Ltd.
 489 (Hwasu-dong), Injung-ro, Dong-Gu,
 Incheon, Korea(22502)
www.doosaninfracore.com/ce/

Copyright 2019. Doosan Infracore. All rights reserved.

Materials and Specifications in the catalogue are subject to change without notice.